

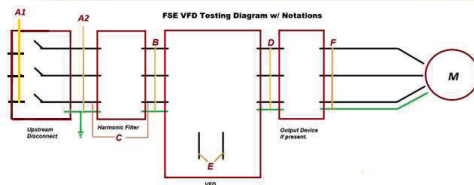

**“An Ounce of Testing Can Save  
a Pound of Cure”**

**A Discussion of Requirement  
for and Benefits of Specification  
of a New Installation and  
Retrofit Testing Protocol for LV  
VFD/ASD Projects**



Start-up and Retrofit Testing for LV VFD/ASD Applications



1

## Introduction

There is an old saying, *“An ounce of prevention is worth a pound of cure!”* and for new and retrofit VFD/ASD installations and routine maintenance, this truism seems to have been forgotten. Within most new installation VFD applications and most routine maintenance activities, detailed testing is not included. The only way to ascertain proper operation of a VFD/ASD to a particular application or within any given circuit is to perform line and load testing, reviewed by an engineer.

The objective of the testing program is to determine that the VFD/ASD installation is designed and installed to coordinate properly within the circuit into which it is being deployed and that the VFD/ASD circuit is programmed and functioning properly without component issues, providing the function and operation intended. Real world installations can impact on the VFD/ASD ability to function properly and the VFD/ASD operation, programming, and set up can have coordination issues with the circuit into which it is being deployed.

Start-up and Retrofit Testing for LV VFD/ASD Applications



2

2

## Segments



Strategic Advantages of Start-up and Routine Maintenance Testing



Fundamental Segments for VFD Testing Discussion



The FSE Test Diagram & Protocol

Start-up and Retrofit Testing for LV VFD/ASD Applications



3

3

## Strategic Advantages of Start-up and Routine Maintenance Testing

- Confirmation of Design, Engineering and Proper Installation**  
Performing a normal Start-up, without a testing protocol, does not qualify the VFD's design, engineering or proper installation. The only way to qualify all three factors is to test line/load and component coordination to determine proper operation.
- Verification of Suitability of the VFD Assembly to Primary and Secondary Circuit "Real World" Conditions**  
Confirmation that the VFD/ASD assembly can perform well based on existing circuit topologies is critical. Assuring the VFD assembly can handle line side power quality conditions such as Vthd-bg (Source background voltage distortion, voltage imbalances and resonance factors) is critical. Also, confirming the output waveform of the inverter is compatible with the secondary circuit condition and load structure is also critical.
- Verification of Start-up and VFD Settings for the Intended Purpose**  
By properly setting up the VFD to the circuit performance needs is required for proper "trip free" operation and enhanced operating efficiency. Properly setting current limits, ramp and decel characteristics and a host of other coordination is best achieved with data to support your settings.

Start-up and Retrofit Testing for LV VFD/ASD Applications



4

4

## The FSE Test Diagram & Protocol

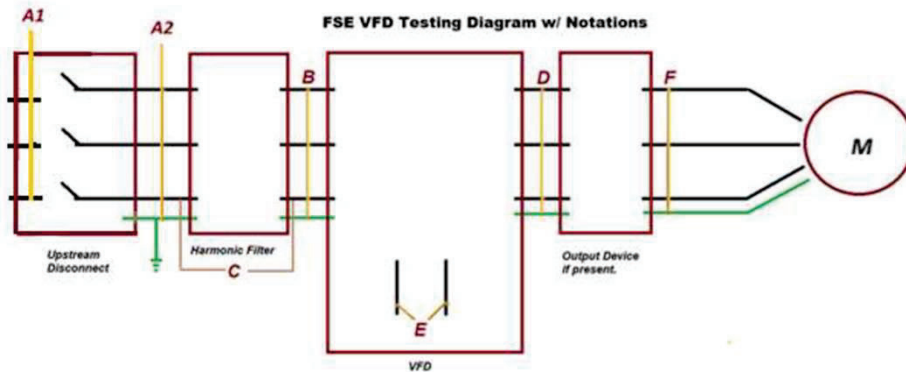

Start-up and Retrofit Testing for LV VFD/ASD Applications



5

5

## Fundamental Segments for VFD Testing Discussion

- **A1 Protocol:** Incoming/Source Condition
- **A2 Protocol:** Harmonic Performance Documentation, Confirmation of Non-Resonance Conditions during operation, VFD balanced current and voltage operation.
- **B Protocol:** Confirmation of line side assemblies, proper operation of line side components, compatibility of with the Source with the VFD and testing proper operation of the VFD component itself.
- **C Protocol:** Typically, this is a comparative of test data from A2 and B protocols, but can involve testing should anomalies be witnessed.
- **D Protocol:** Output Verification for the VFD to confirm proper PWM output waveform, inspect for the presence of resonance/ringing or transient/surge potential conditions, and to check for balanced voltage source and current draw conditions. Used for diagnostics of the VFD component and to verify proper operation of the load circuit.

Start-up and Retrofit Testing for LV VFD/ASD Applications



6

6

## Fundamental Segments for VFD Testing Discussion

- **E Protocol:** VFD DC bus measurements. VFD DC Bus Testing should only be performed by the manufacturer's designated service/start-up contractor since disassembly or the VFD may be required to access a proper test termination location. Typically recommended when anomalies are witnessed which would indicate a potential malfunction or improper operation of the VFD component itself.
- **F Protocol:** If the VFD circuit is equipped with an output device such as an output inductor, dv/dt filter, sinewave filter, or common mode choke, the testing is recommended to diagnose these components when compared with Protocol D testing results for current and voltage balance, resonance/ringing, or other errant measurements.

7

## Fundamental Segments for VFD Testing Discussion

### Key Concepts

- By collecting the testing data via an organized format and establishing comparative criteria between the protocols it allows for a clear understanding of the operation of the VFD under real load conditions allowing for confidence in proper design and deployment.
- During the testing protocol, immediate witnessing of operating challenges can be determined which will allow for "immediate action" to prevent potentially damaging component, process conditions, and safety challenges.
- Proper operation of the VFD and load structures along with maintaining the Source distribution assures the most efficient operation of the intended process/load energy consumption.

8

## The FSE Test Diagram & Protocol

The minimum required test data noted to the right is normal data that can be easily captured by a qualified Power Quality Meter with a minimum of effort.

In the case of an AEMC 8336 meter or similar instrument, when you hit the record button, all the data noted within the detail is automatically recorded including the wave trace without special programming or extra effort.

Minimum Required Test Data:

- Power Recorded Data must include:
  - Displacement and Total/True Power Factor
  - kW – True Power
  - kW-DC – DC True Power if Applicable
  - kVA – Apparent Power
  - Vector Analysis
- Voltage Recorded Data must include:
  - A minimum of a one cycle three phase wave trace
  - Voltage Peak by Phase
  - Voltage Nominal by Phase
  - Vthd: Total Harmonic Distortion
  - Vthd Integer Harmonic Measurement by value and % of fundamental through the prescribed test frequency range.
  - Data must be collected for P/P, P/G-N and Grd for all measurement requirements above.
- Current Recorded Data must include:
  - A minimum of a one cycle three phase wave trace
  - Peak Current by Phase
  - Nominal Current by Phase
  - Ithd: Current Total Harmonic Distortion
  - Ithd Integer Harmonic Measurement by value and % of fundamental through the prescribed test frequency range.
  - Data must be collected for each individual phase and for the equipment ground.

## The FSE Test Diagram & Protocol

**Point A1 Testing Protocol:**

Line side Test A1 is used to determine the Source Background Voltage Distortion and Source Voltage Imbalance. This information is then used to help qualify the results from input and output testing results (A2 through E) and to qualify the relative health of the source circuit condition.

- With the VFD off & de-energized and any VFD line side capacitance reactance isolated, test and record the Vthd-bg and Vimb within the circuit. These measurements will be recorded Phase to Phase and Phase to Ground
- Voltage Recorded Data must include:
  - A minimum of a one cycle three phase wave trace
  - Voltage Peak by Phase
  - Voltage Nominal by Phase
- Vthd: Total Harmonic Distortion;
  - Vthd Integer Harmonic Measurement by value and % of fundamental through the prescribed test frequency range.
- Ground Current and Voltage should be recorded including a harmonic spectrum and wave trace to determine if common mode noise is problematic within the installation.

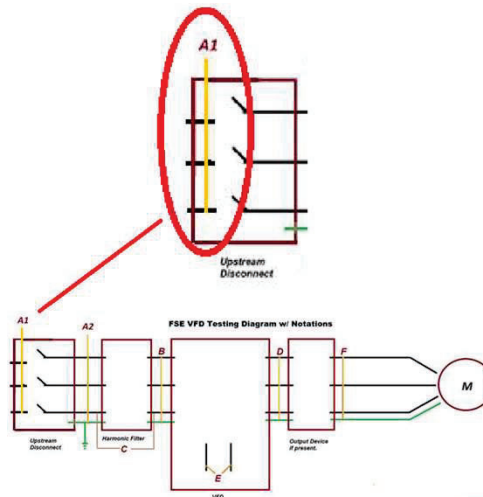

## The FSE Test Diagram & Protocol

### Point A2 Testing Protocol:

Line Side Test A2 is used to measure Current and Voltage (P-P & P-G/N) and record wave traces and data relative to:

- IEEE519-2022 Harmonic compliance of the VFD at Nominal load, Voltage & Current including harmonic spectrum analysis through the 50th Harmonic, for SCR and diode bridge rectifiers and through **2.5X the switching frequency of the Active/IGBT Rectifiers and/or assemblies.**
- Minimum Required Test Data:  
See schedule Power Recorded Data, Voltage Recorded Data, & Current Recorded

**Data must be collected for each individual phase and for the equipment ground. Ground Current and Voltage should be recorded including a harmonic spectrum and wave trace to determine if common mode noise is problematic within the installation.**

- This test will provide the IEEE519 comparative, indication of resonance conditions due to VFD assembly operation or interaction with the source, the presence or potentially problematic common mode conditions, and VFD assembly integrity.

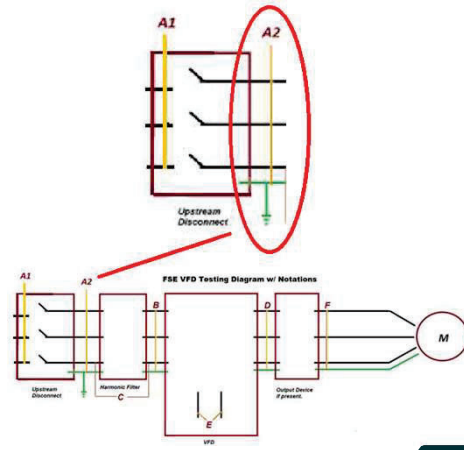

## The FSE Test Diagram & Protocol

### Point B Testing Protocol:

If the VFD is equipped with a line side passive harmonic filter or AC line reactor, measurements should be taken at the output of this filter/inductor unit for diagnostics of the filter/line reactor and as a diagnostic tool for the VFD without the influence of that line side assembly.

- IEEE519-2022 Harmonic compliance of the VFD at Nominal load, Voltage & Current including harmonic spectrum analysis through the 50th Harmonic, for SCR and diode bridge rectifiers and through **2.5X the switching frequency of the Active/IGBT Rectifiers and/or assemblies.**
- Minimum Required Test Data:  
See schedule Power Recorded Data, Voltage Recorded Data, & Current Recorded
- Data must be collected for each individual phase and for the equipment ground. Ground Current and Voltage should be recorded including a harmonic spectrum and wave trace to determine if common mode noise is problematic within the installation.

### Point C Comparative Analysis:

*A comparative analysis of A2 measurements versus B measurements can be examined within a like phase analysis should voltage and/or current anomalies be present. This comparative allows for determination of proper operation of the line reactor/inductor/passive harmonic filter versus the VFD itself. It will be the responsibility of the test engineer and/or tech to determine if additional testing is warranted should initial review at time of A2 and B testing indicate a potential issue with an upstream impedance source downstream of the primary disconnect (Test Point A2) and the VFD input terminals (Test Point B).*

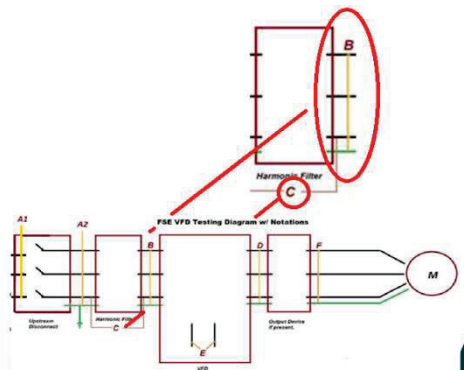

## The FSE Test Diagram & Protocol

**Point D Testing Protocol:**

On the output of the VFD, upstream of any secondary devices such as output inductors, dv/dt filters, sinewave filters, and/or common mode chokes, test the output of the VFD including harmonic profile of the VFD at Nominal load, Voltage & Current including harmonic spectrum analysis through the 50th harmonic as a minimum. If anomalies are present, higher frequency analysis through the switching frequency of the inverter would be advised. Wave trace of the current and voltage is strongly recommended as a visual confirmation of proper PWM output waveform condition and to assure there is no evidence of secondary resonance/reflective wave conditions present.

- Minimum Required Test Data:  
See schedule Power Recorded Data, Voltage Recorded Data, & Current Recorded
- Data must be collected for each individual phase and for the equipment ground. Ground Current and Voltage should be recorded including a harmonic spectrum and wave trace to determine if common mode noise is problematic within the installation.

**Point E Testing Note:**

*VFD DC Bus Testing should only be performed by the manufacturer's designated service/start-up contractor since disassembly or the VFD may be required to access a proper test termination location. This testing should be initiated when: (1) Secondary voltage measurement during Protocol D or F testing indicates a significant voltage imbalance that cannot be explained by source measurements under Protocol A1/A2 and B testing; (2) Current Imbalances or oscillating voltage and current patterns under protocols A2, D or F testing are witnessed; (3) If a high frequency current or voltage resonance is present during A2 or B protocol testing; (4) Or if a high frequency resonance/secondary is observed during Protocol D & F testing.*

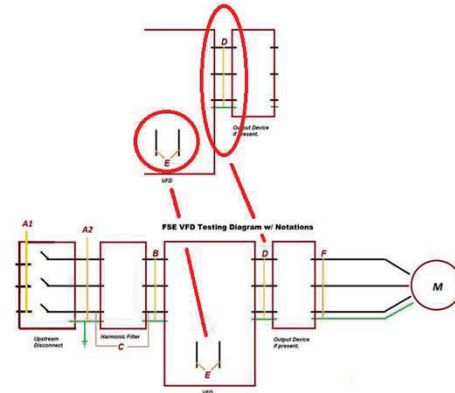

## The FSE Test Diagram & Protocol

**Point F Testing Protocol:**

- If the VFD is equipped with either an output inductor, dv/dt filter, sinewave filter, or common mode choke/filter: repeat testing followed under D Testing Protocol on the output of the secondary device. This data can be used to ascertain proper operation and coordination of the equipment to the VFD and secondary circuit topology, harmonic profile of the VFD at Nominal load, and Voltages & Current including harmonic spectrum analysis through the 50th harmonic as a minimum. If anomalies are present, higher frequency analysis through the switching frequency of the inverter would be advised. Wave trace of the current and voltage is strongly recommended as a visual confirmation of proper PWM output waveform condition and to assure there is no evidence of secondary resonance/reflective wave conditions present.

- Minimum Required Test Data:  
See schedule Power Recorded Data, Voltage Recorded Data, & Current Recorded
- Data must be collected for each individual phase and for the equipment ground. Ground Current and Voltage should be recorded including a harmonic spectrum and wave trace to determine if common mode noise is problematic within the installation.

*A comparative of the D Point data versus the F measurements is key to determining the proper operation of the output devices if present. It will also aid in diagnosing the source of resonance/ringing if present. This testing protocol is key to finalizing a comprehensive examination of the installation and operation of the assembly.*

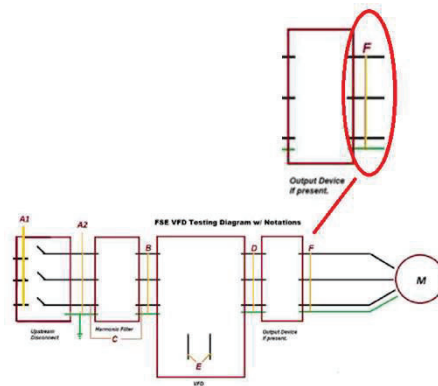

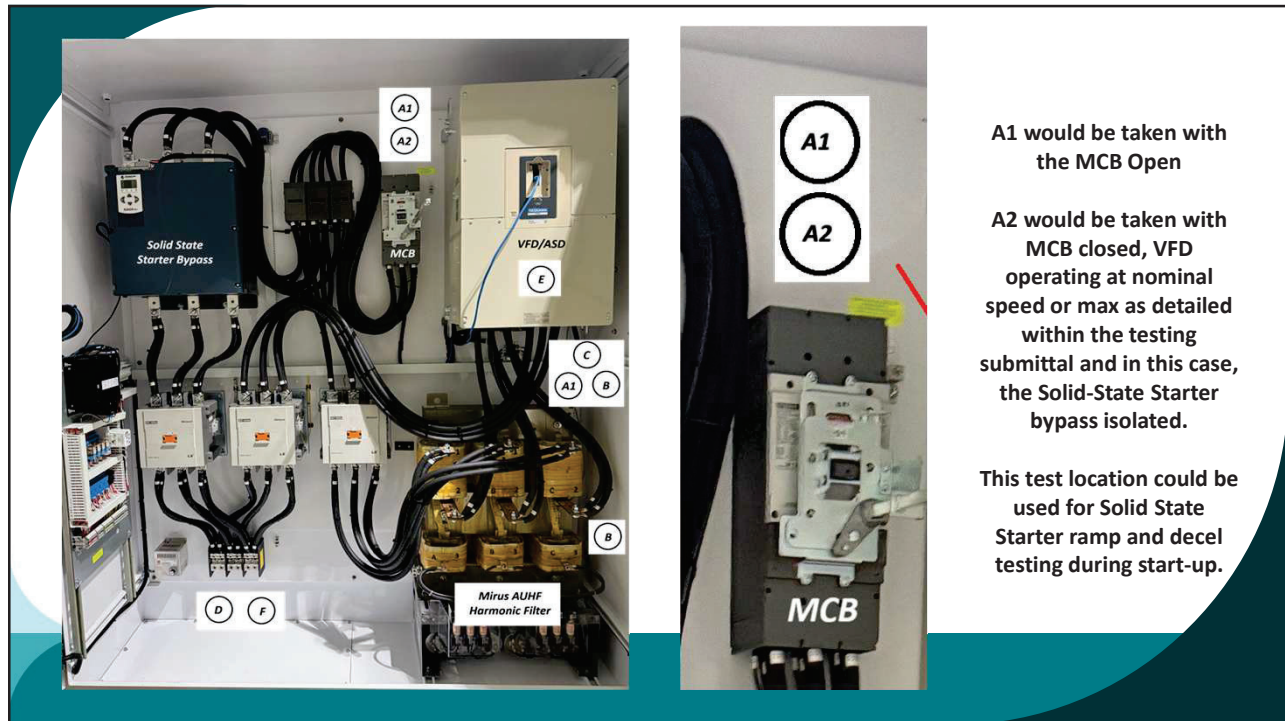

A1 would be taken with the MCB Open

A2 would be taken with MCB closed, VFD operating at nominal speed or max as detailed within the testing submittal and in this case, the Solid-State Starter bypass isolated.

This test location could be used for Solid State Starter ramp and decel testing during start-up.

15

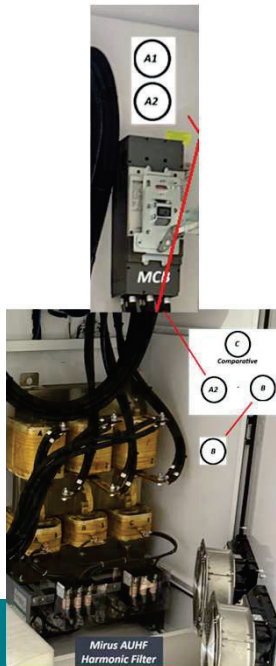
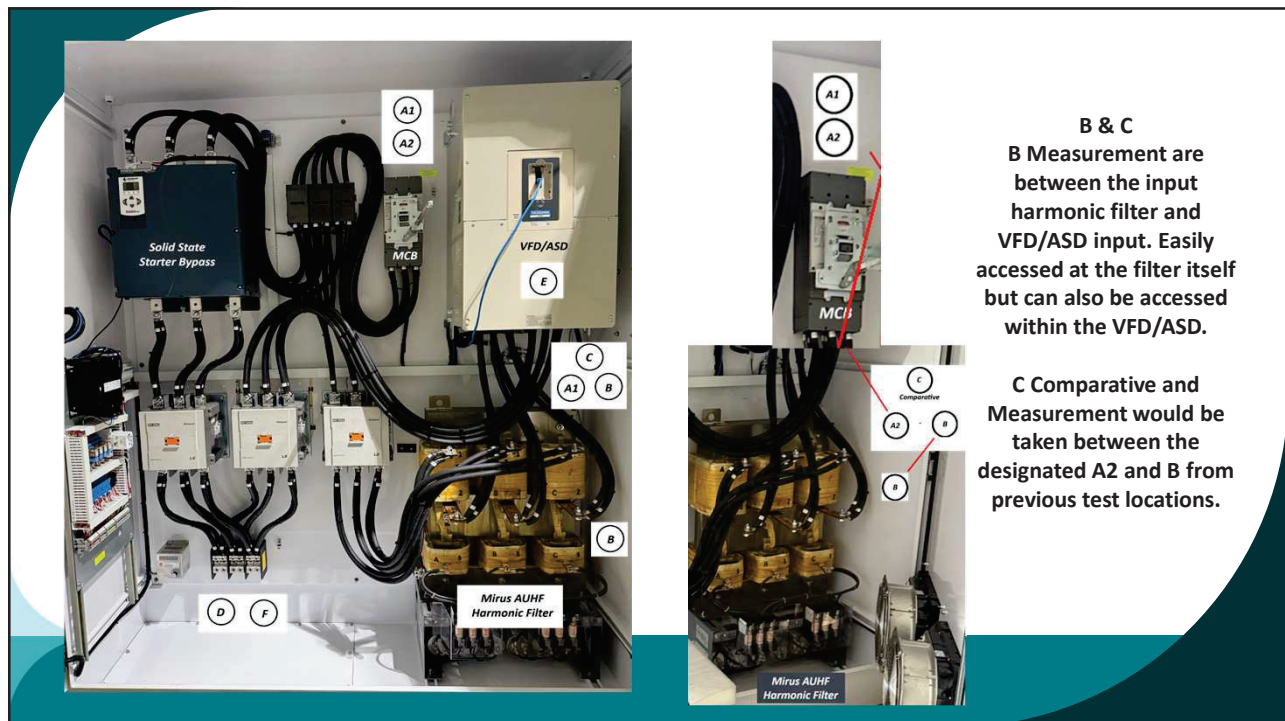

**B & C**

B Measurement are between the input harmonic filter and VFD/ASD input. Easily accessed at the filter itself but can also be accessed within the VFD/ASD.

C Comparative and Measurement would be taken between the designated A2 and B from previous test locations.

16

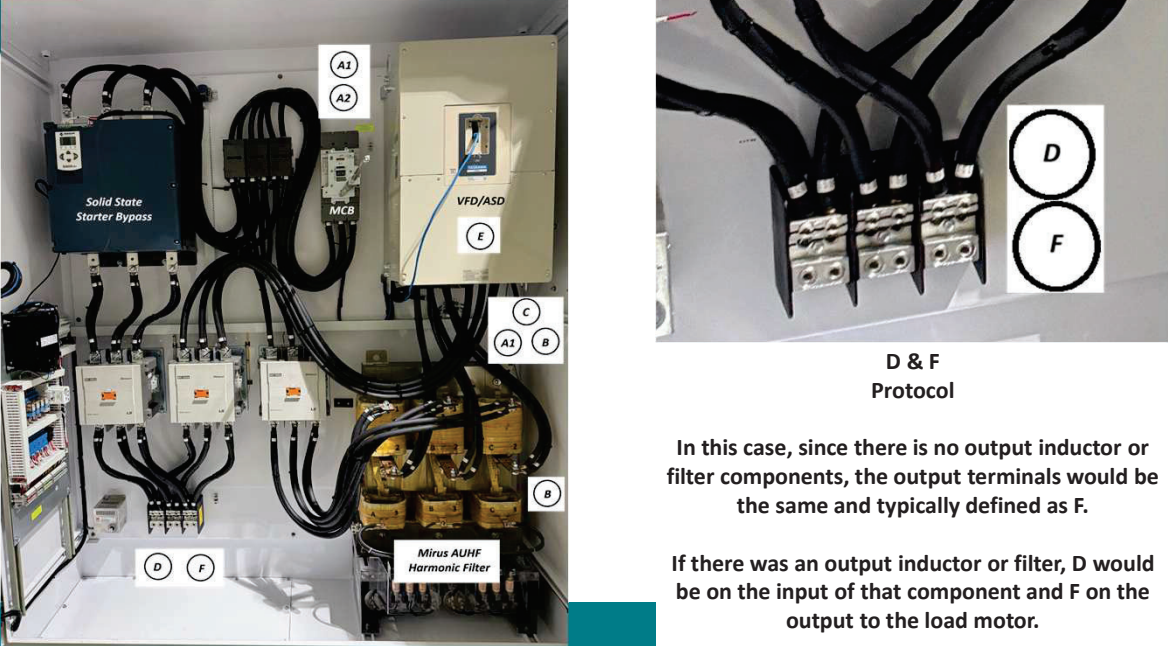

**D & F Protocol**

In this case, since there is no output inductor or filter components, the output terminals would be the same and typically defined as F.

If there was an output inductor or filter, D would be on the input of that component and F on the output to the load motor.

17

## The FSE Test Diagram & Protocol

Since VFD/ASD installations comes in numerous configurations to fit the circuit requirement:

- Each drive configuration should be identified and detailed. Within the submittal and test reports.
- Individual test protocols should be submitted by the contractor/start-up engineering group for review and approval.
- The associated test reports must include a configuration and description of the test protocol to allow for qualified review and approval.
- Image records of the equipment, device designation and associated serial numbers should be documented for future reference during maintenance testing and diagnostic activities.

18

## The Recommended FSE Test Specification

### 1.01 SCOPE

- A. This specification covers the requirements for all retrofit and new installation LV VFD/ASD start-up testing and acceptance.
- B. This specification defines minimum requirements, characteristic guidelines, and reporting format required.

### 1.02 SUBMITTALS

- A. Submit proposed start-up and test protocols and outline to be performed associated with the VFD/ASD new and retrofit installations. Qualification of whether the Start-up and/or Testing will be performed by the equipment manufacturer, service entity, and/or electrical contractor is required.

### 2.01 GENERAL

- A The start-up and maintenance testing contractor / entity shall be prequalified and approved to perform service by the end user, consulting engineer, and/or integrator and demonstrate service and start-up programming experience for the VFD/ASD brand of equipment.
- B Testing shall be performed following appropriate safety protocols and procedures as prescribed by industry standard.
- C Testing shall be performed following the protocol testing structure as shown in the below diagram and within the schedule as shown in Part 2, 2.01.D.

## The Recommended FSE Test Specification

D Description required testing and data collection per protocol schedule Part 2, 2.01 para. C above.

Protocol and Parameter	Test Parameter & Value
A1: Source Background Vthd & Vimb (VFD de-energized and any load equipment capacitance reactance isolated from circuit). (1)	Vthd & V imbalance
A2: Input Harmonic and test data line side of VFD with any impedance or harmonic mitigation applied. Testing to be performed at nominal load or full load based on application. (2)	Ithd, Current imbalance, Vthd, Voltage imbalance, Grd. Current and Voltage Levels. Harmonic Spectrums and Wave Trace shall be recorded within the testing data.
B: VFD Input Harmonic and test data line side of VFD load side of impedance or harmonic mitigation applied. Testing to be performed at nominal load or full load based on application. (2)	Ithd, Current imbalance, Vthd, Voltage imbalance, Grd. Current and Voltage Levels. Harmonic Spectrums and Wave Trace shall be recorded within the testing data.
C: Comparative Notes and Discussion of A2 versus B measurement data. (2)	Specific measurements may be required if anomalies or abnormal test values are present at either A2 or B test points.
D: VFD Inverter Output Harmonics and test data. Testing to be performed at nominal load or full load based on application. (2)	Ithd, Current imbalance, Vthd, Voltage imbalance, Grd. Current and Voltage Levels. Harmonic Spectrums and Wave Trace shall be recorded within the testing data.
E: VFD DC Bus Ripple Measurements and Notes	Testing at E shall be initiated should the VFD/ASD Mfg. require a DC bus measurement should errant, anomalies or abnormal test results present at any time during the start-up and test protocol.
F: VFD-Assembly Harmonics and Test Data Secondary of any output impedance or power conditioning equipment. Testing to be performed at nominal load or full load based on application. (2)	Ithd, Current imbalance, Vthd, Voltage imbalance, Grd. Current and Voltage Levels. Harmonic Spectrums and Wave Trace shall be recorded within the testing data.

The protocol points may not be required for each installation, circumstance, or program. A submittal of the contractor/service test proposal must be reviewed and approved prior to testing. The proposal should also address:

- (1) Harmonic verification testing must be performed on the circuit branch feeding the intended test load to assure accuracy for the intent of the test program. Clear delineation of the testing point for this test must be detailed/approved within the test plan submittal and within the test report detail.
- (2) Full Load Conditions during testing for points A2, B, C, D, & F should be utilized unless FLC cannot be achieved due to operational constraints. Nominal load or max available load may be utilized as approved. Other options include a % load format which may be required for diagnostic evaluations. Load conditions must be addressed within the test plan submittal & approved by the Engineer.
- (3) The test plan submittal must address testing of all available power sources including multiple utility feeds and backup generator.

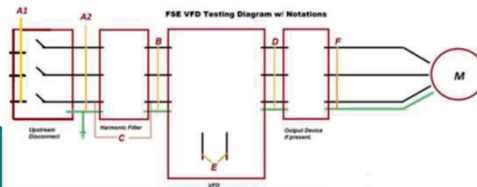

## The Recommended FSE Test Specification

E. If Active Harmonic Mitigation technology is utilized (i.e. either Active Harmonic Filters or Active Front End Drives) within the associated load circuit, all harmonic measurements must be performed through 2.5x the switching frequency of the harmonic filter or IGBT rectification as programmed.

F. Output testing for testing points D and F can be performed at 3 kHz (through the 50th harmonic).

### 2.03 Testing Report Requirements

A. Project Info and Reference Section: Must include, Customer Name, Project/Job Reference, Project Name, Site Name with location, Customer Contact information, Onsite Tech Name, Test Data File references, Test Date, Report Author, and Report Date.

B. Report shall include a detail of the purpose of the testing program including description of site circumstances or conditions.

C. A detail of the testing plan and description of circumstances relative to the actual site tests program.

D. Test Equipment Identification including brand, model and last certified calibration date.

E. Tested Equipment Identification and Documentation: Organized by circuit, a detail listing of the electrical components within the tested circuit shall be provided including component name, manufacturer, serial number, and ratings detail from the equipment nameplates and data sheets.

F. Test Results Executive Summary: This will be organized by site and/or circuit. The results must include a brief explanation of the test results, highlighting if the observed data/results were normal or abnormal, in compliance with appropriate performance and operational standards, and any/all unusual operational conditions are observed or experienced during the testing or during the review of the data.

21

## The FSE Test Diagram & Protocol

G. *Testing Documentation & Observed Results Schedule: Organized by test load/equipment a test summary organized by test protocol, test parameter with test value, pass/fail grading, and notes as to observed condition as detailed in Part 2.01.D. The below format is an example only.*

H. *Conclusion/Recommendation Discussion: An overall conclusion and detail of recommendations based on compliance, operational or systemic issues observed/recorded of the testing.*

### 3.01 ACCEPTANCE

A. *The Start-up testing report shall be submitted for review and approval. If further qualification of the results and data are required, the testing entity may be required to provide further detail including raw data and associated electronic files for review.*

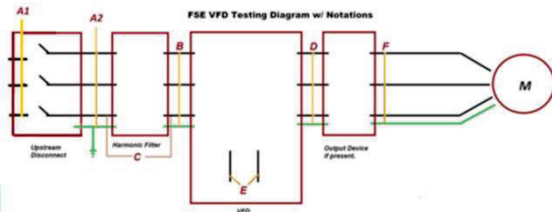

Site, Equipment, Testing Date & Time Stamp	Color Code	Protocol and Parameter	Test Parameter & Value	Notes
		A1: Source Background Vthd & Vimb	Vthd: Vimbalance:	
		A2: Input Harmonic and test data line side of VFD with any impedance or harmonic mitigation applied.	Ithd: Current imb.: Vthd: Voltage imb.: Grid Current Level:	
		B: VFD Input Harmonic and test data line side of VFD load side of impedance or harmonic mitigation applied.	Ithd: Current imb.: Vthd: Voltage imb.: Grid Current Level:	
		C: Comparative Notes and Discussion of A2 versus B measurement data.		
		D: VFD Inverter Output Harmonics and test data	Ithd: Current imb.: Vthd: Voltage imb.: Grid Current Level:	
		E: VFD DC Bus Ripple Measurements and Notes	Ithd:	
		F: VFD Assembly Harmonics and Test Data Secondary of any output impedance or power conditioning equipment	Current imb.: Vthd: Voltage imb.: Grid Current Level:	

22

# Questions?

23



**Presenter/Author Biography**



**Michael McGraw –Primary Author :** Currently Business Development and Engineering Services Five Star Electric. Previously US Regional Manager for Mirus International, from 2018 – 2022, Independent Engineering representative for Mirus International from 2009 – 2018, and President and Founder of NSOEM, Inc. 1996 - 2018 He is a member of the IEEE – IAS and has previously published IEEE papers presented at the PCIC 2010, 2014, 2015, 2016, 2018, 2019 & 2024. IEEE/PCIC 2025 - 3 Hour Tutorial Primary Author & Presenter: “Harmonic Engineering & Design Challenges for Distribution Circuit and Grid Design” <https://www.linkedin.com/in/mike-mcgraw-bb8a6760/>

**Technical References:**

- FSE-MM-10202025-LV-VFD-Testing-Guide: Start-up and Retrofit Testing for LV VFD/ASD Applications “An Ounce of Testing Can Save a Pound of Cure”
- PCIC-IEEE-2025-5-Tutorial-FSE-Mirus: Tutorial - Harmonic Challenges for Distribution Grid Design
- Texas-Water-2025\_VFDs-and-Harmonic-Mitigation-in-Modern-Water-Wastewater-Applications-Presentation-2093
- Intuitive Understanding of Harmonics 210624, Mirus International, Michael A McGraw

24

# FSE Contact Directory



SAN ANTONIO	HOUSTON	LUBBOCK
Engineering & Manufacturing	Sales	Manufacturing & Warehouse
Address: 11135 Iota Drive San Antonio, TX 78217 Phone: +1-210-492-4200	Address: Houston, TX 77084 Phone: +1-281-492-7090	Address: 14503 North Interstate 37 Lubbock, TX 79403 Phone: +1-806-252-9700

Patrick McGinty: Sales Manager/Principal  
281-467-9113, [pmcginty@vfd.com](mailto:pmcginty@vfd.com)

Russ Brehm: Service Manager  
602-363-9375, [rbrehm@vfd.com](mailto:rbrehm@vfd.com)

Mark Hajda: Director of Sales  
210-568-8940, [mark@vfd.com](mailto:mark@vfd.com)

Shannon Lux: Sales  
210-568-8928, [shannon@vfd.com](mailto:shannon@vfd.com)

Chuck Stewart: Sales  
830-832-0525, [chuck@vfd.com](mailto:chuck@vfd.com)

Jason McKinley: SE TX Sales  
713-516-4078, [jason@vfd.com](mailto:jason@vfd.com)

Tery Lewis: WTX Sales  
806-252-9700, [tlewis@vfd.com](mailto:tlewis@vfd.com)

Jack Dolman: NTX Sales  
469-563-8943, [jdolman@vfd.com](mailto:jdolman@vfd.com)

Mike McGraw, Engineering Consultant  
713-208-8534, [mmcgraw@vfd.com](mailto:mmcgraw@vfd.com)

25

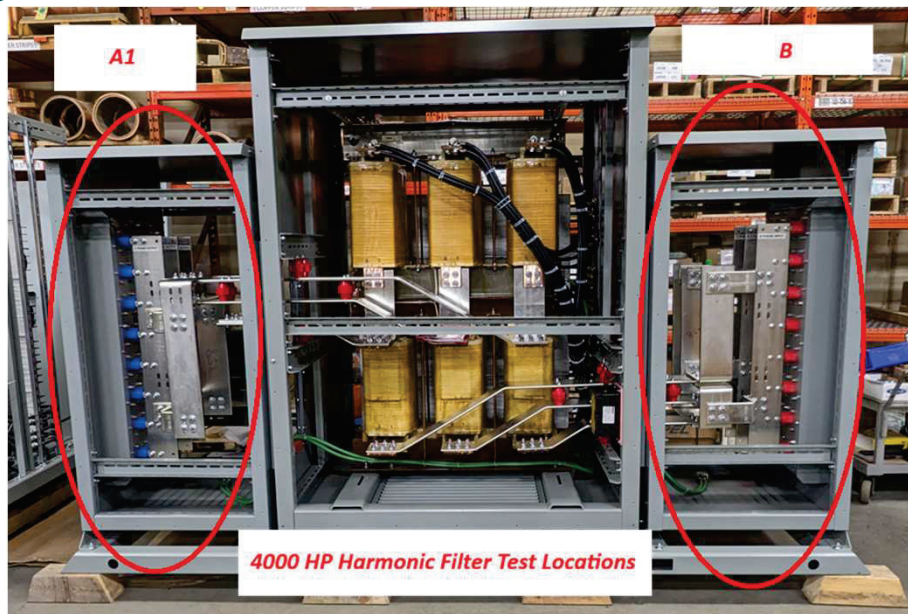

Start-up and Retrofit Testing for LV VFD/ASD Applications



26

26